

**N°07-UL**
**Data/Date: 6<sup>th</sup> December 2007**
**page 1 of 2**

<b>Informazione</b> <i>Information</i>	<input type="checkbox"/>	<b>Raccomandazione</b> <i>Recommendation</i>	<input checked="" type="checkbox"/>	<b>Prescrizione</b> <i>Mandatory</i>	<input type="checkbox"/>
---	--------------------------	---	-------------------------------------	---	--------------------------

<b>VELIVOLI INTERESSATI</b> <i>A/C AFFECTED</i>	<b>P2002 (serie with fixed gear )</b> <i>P2002 (serie con carrello fisso)</i>
<b>TERMINI DI ESECUZIONE</b> <i>TIME OF COMPLIANCE</i>	Alle prossime 100 ore. <i>At the next 100 flight hours</i>
<b>LUOGO DI ESECUZIONE</b> <i>WORKING PLACE</i>	Sul posto. <i>On place.</i>

**OGGETTO:** Viti attacco carrello principale.

**Subject:** *Main landing gear attachment bolts*
**SCOPO:** Al fine di migliorare il collegamento tra le balestre del carrello principale e la fusoliera è possibile sostituire le viti installate a normativa UNI con nuove viti a standard MS..

**Scope:** *In order to improve the connection between the main landing gear leaf-springs and the fuselage, it is possible to replace the installed bolts at normative UNI with new ones at standard MS.*

<b>N</b>	<b>Istruzioni / Instruction</b>																		
<b>1</b>	<p>For the P2002 Sierra aircraft a new kit shown in Fig.1 is available:</p> <table border="1"> <thead> <tr> <th><i>DESCRIPTION</i></th> <th><i>Part number</i></th> <th><i>Quantity</i></th> </tr> </thead> <tbody> <tr> <td>Central bolt</td> <td>MS20006-27</td> <td>2</td> </tr> <tr> <td>Lateral bolt</td> <td>MS20005-27</td> <td>4</td> </tr> <tr> <td>Locknut (7.9mm)</td> <td>MS21042-5</td> <td>4</td> </tr> <tr> <td>Locknut (9.5mm)</td> <td>MS21042-6</td> <td>2</td> </tr> <tr> <td>Flaring washer (7.9mm)</td> <td>MS20002C-5</td> <td>4</td> </tr> </tbody> </table>	<i>DESCRIPTION</i>	<i>Part number</i>	<i>Quantity</i>	Central bolt	MS20006-27	2	Lateral bolt	MS20005-27	4	Locknut (7.9mm)	MS21042-5	4	Locknut (9.5mm)	MS21042-6	2	Flaring washer (7.9mm)	MS20002C-5	4
<i>DESCRIPTION</i>	<i>Part number</i>	<i>Quantity</i>																	
Central bolt	MS20006-27	2																	
Lateral bolt	MS20005-27	4																	
Locknut (7.9mm)	MS21042-5	4																	
Locknut (9.5mm)	MS21042-6	2																	
Flaring washer (7.9mm)	MS20002C-5	4																	
<b>2</b>																			

**N°07-UL**

**Data/Date: 6<sup>th</sup> December 2007**

**page 2 of 2**

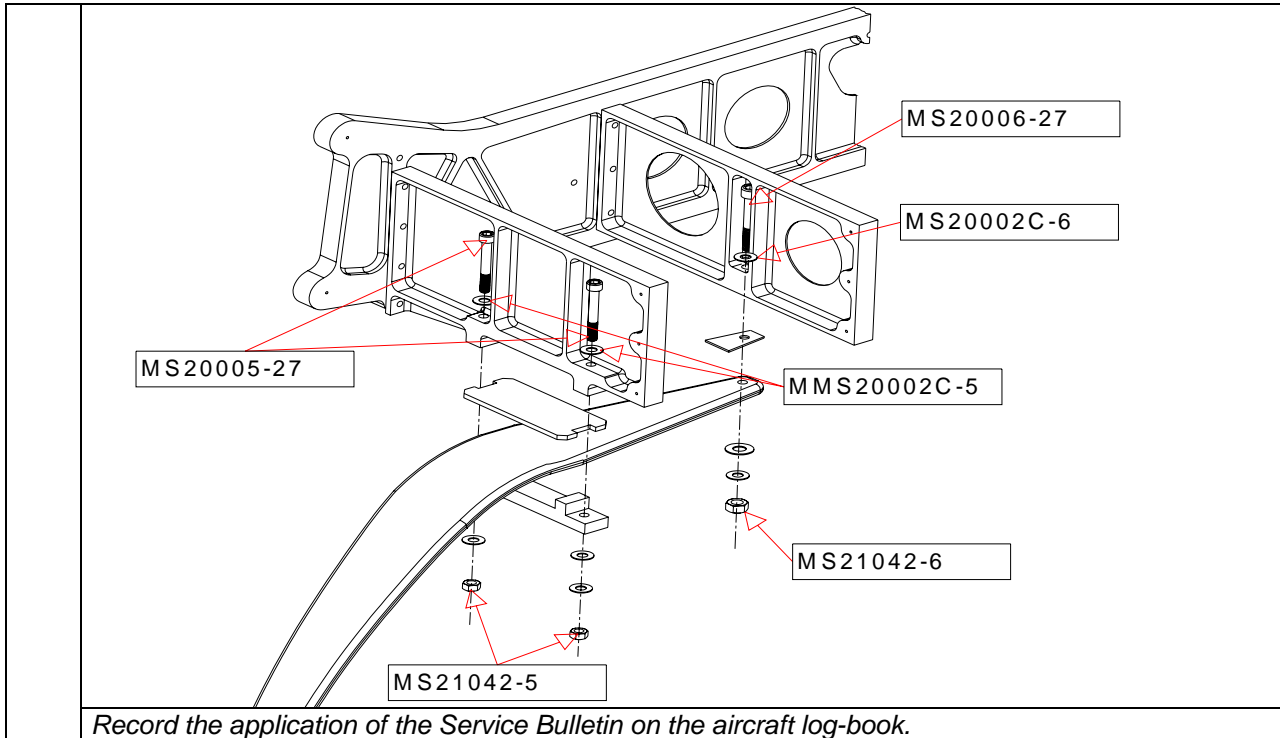

*For further information, please contact Tecnam:*

*Tel +39 081 7583210; Fax +39 081 7584528; E-mail [p.violetti@tecnam.com](mailto:p.violetti@tecnam.com); [m.oliva@tecnam.org](mailto:m.oliva@tecnam.org)*