

SERVICE BULLETIN
CHECKING OR REPLACEMENT
OF FUEL PUMP PART NO. 892230/892235
FOR ROTAX® ENGINE TYPE 912 (SERIES)
SB-912-050UL

MANDATORY

Repeating symbols:

Please, pay attention to the following symbols throughout this document emphasizing particular information.

- ▲ **WARNING:** Identifies an instruction, which if not followed, may cause serious injury or even death.
- **CAUTION:** Denotes an instruction which if not followed, may severely damage the engine or could lead to suspension of warranty.
- ◆ **NOTE:** Information useful for better handling.

1) Planning information

1.1) Engines affected

All versions of the engine type:

- 912 UL from S/N 4,407.646 to S/N 4,407.847
- 912 ULS from S/N 5,646.084 to S/N 5,646.550
- 912 ULSFR from S/N 4,430.267 to S/N 4,430.307

Following engines are not affected:

- 912 ULS from S/N 5,646.517 to S/N 5,646.526

all parts

- Fuel pump, part no. 892230 and 892235, which was supplied as a spare part.

In addition are also effected, all engines and gearboxes installed with fuel pump part no. 892230 or 892235, has installed at engine repair/general overhaul.

- ◆ **NOTE:** All engines and gearboxes were already retrofitted with fuel pump part no. 892232 or 892236 are not affected.

For complete instructions and compliance to this service bulletin refer to Service Bulletin-SB-912-050, latest edition section 1.2 onward.

- ◆ **NOTE:** Section 1.6) Approval: Is not required for engines of the type UL (Series).
Section 3) Accomplishment: In addition: persons with adequate type-specific training.

SERVICE BULLETIN

CHECKING OR REPLACEMENT

OF FUEL PUMP PART NO. 892230/892235

FOR ROTAX® ENGINE TYPE 912 (SERIES)

SB-912-050

MANDATORY

Repeating symbols:

Please, pay attention to the following symbols throughout this document emphasizing particular information.

▲ **WARNING:** Identifies an instruction, which if not followed, may cause serious injury or even death.

■ **CAUTION:** Denotes an instruction which if not followed, may severely damage the engine or could lead to suspension of warranty.

◆ **NOTE:** Information useful for better handling.

1) Planning information

1.1) Engines affected

All versions of the engine type:

- 912 A from S/N 4,410.684 to S/N 4,410.686
- 912 F S/N 4,412.913
- 912 S from S/N 4,923.282 to S/N 4,923.301

all parts

- Fuel pump, part no. 892230 and 892235, which was supplied as a spare part.

In addition are also effected, all engines and gearboxes installed with fuel pump part no. 892230 or 892235, has installed at engine repair/general overhaul.

◆ **NOTE:** All engines and gearboxes were already retrofitted with fuel pump part no. 892232 or 892236 are not affected.

1.2) Concurrent ASB/SB/SI and SL

none

1.3) Reason

In limited cases a production deviation of the fuel pump can result in exceeding of the fuel pressure.

1.4) Subject

Checking or replacement of fuel pump part no. 892230/892235 for ROTAX® engine type 912 (Series).

1.5) Compliance

- At first 25^h-inspection.
- At the next inspection, if the TSN by 25^h has already been passed.
- At the latest December 31st 2006.

▲ **WARNING:** Non-compliance with these instructions could result in engine damages, personal injuries or death.

1.6) Approval

The technical content is approved under the authority of DOA Nr. EASA.21J.048.

1.7) Manpower

Estimated man-hours:

Engine installed in the aircraft - - -manpower time will depend on installation and thus, no estimate is available from the engine manufacturer.

1.8) Mass data

Change of weight - - - none.

Moment of inertia - - - unaffected.

1.9) Electrical load data

No change

1.10) Software accomplishment summary

No change

1.11) References

In addition to this technical information refer to current issue of

- Operator's Manual (OM)
- Illustrated Parts Catalog (IPC)
- Maintenance Manual (MM)

1.12) Other publications affected

none

1.13) Interchangeability of parts

All used parts which cannot be used must be returned F.O.B. to a ROTAX[®] Authorized Distributors or Service Centers.

2) Material Information

2.1) Material - cost and availability

Price and availability will be supplied on request by ROTAX[®] Authorized Distributors or their Service Centers.

2.2) Company support information

None

2.3) Material requirement per engine

parts requirement:

Fig.no.	New part no.	Qty/engine	Description	Old part no.	Application
	892232*	1	fuel pump assy.	892230	fuel system
	892236*	1	fuel pump assy. with fuel line	892235	fuel system
	950225	1	gasket	950220	fuel pump

* dependent of engine type (see IPC)

2.4) Material requirement per spare part

None

2.5) Rework of parts

None

2.6) Special tooling/lubricant-/adhesives-/sealing compound - Price and availability

Fig.no.	New part no.	Qty/engine	Description	Old part no.	Application
	874231**	1	fuel pressure test kit	-	fuel system

** or equivalent

3) Accomplishment / Instructions

Accomplishment

All the measures must be taken and confirmed by the following persons or facilities:

- ROTAX[®] -Airworthiness representative
- ROTAX[®] -Distributors or their Service Centers
- Persons approved by the respective Aviation Authority

▲ **WARNING:** Risk of scalds and burns! Allow engine to cool sufficiently and use appropriate safety gear while performing work.

▲ **WARNING:** Should removal of a locking device (namely lock tabs, self-locking fasteners) be required when undergoing disassembly/assembly, always replace with a new one.

3.1) Instructions

■ **CAUTION:** Conduct all subsequent work in accordance with the current Flight Manual or Operators Manual and Maintenance Manual.

3.1.1) Checking fuel pressure

- Start engine as per Flight Manual or Operators Manual and check the fuel pressure in entire speed range. Fuel pressure must be between 0,15 (2,2 psi) and 0,4 bar (5,8 psi).

◆ **NOTE:** If the aircraft is not equipped with a fuel pressure indication, so such to be installed additionally. Fuel pressure test kit are available by ROTAX[®] Authorized Distributors or Service Centers.

If the fuel pressure is correct, only the gasket is to be replaced by new part. See section 3.1.2.

If the fuel pressure is out of the operating limits, the fuel pump including gasket must be replaced. See section 3.1.3.

3.1.2) Replacement of the gasket

Geometry changes of the gasket can result in limited cases in subsidence and leakage. Therefore gasket (2) must be replaced by new part for all engines affected (See Fig 1).

◆ **NOTE:** With some engines also a paper gasket is integrated with the gasket. These are to be exchanged for the new gasket.

Instruction analog to section 3.1.3).

3.1.3) Replacement of the fuel pump

(see Fig.1)

▲ **WARNING:** Proceed with this work only in a non-smoking area and not close to sparks or open flames. Switch off ignition and secure engine against unintentional operation. Secure aircraft against unauthorized operation. Disconnect negative terminal of aircraft battery.

- Remove fuel pump (1).
- Gasket (2) replaced by new part.
- Install fuel pump. Tightening torque 15 Nm (133 in.lb).
- Install fuel line.
- Restore aircraft to original operating configuration.
- Connect negative terminal of aircraft battery.

3.2) Test run

Start Engine. Conduct test run including ignition check and leakage test in accordance with the current Maintenance Manual of the respective engine type.

3.3) Summary

These instructions (section 3) have to be conducted in compliance with section 1.5. Confirm the implementation of the specified Service Bulletin in the Engine Log book.

Approval of translation to best knowledge and judgment - in any case the original text in the German language and the metric units (SI-system) are authoritative.

4) Appendix

The following drawings should provide additional information:

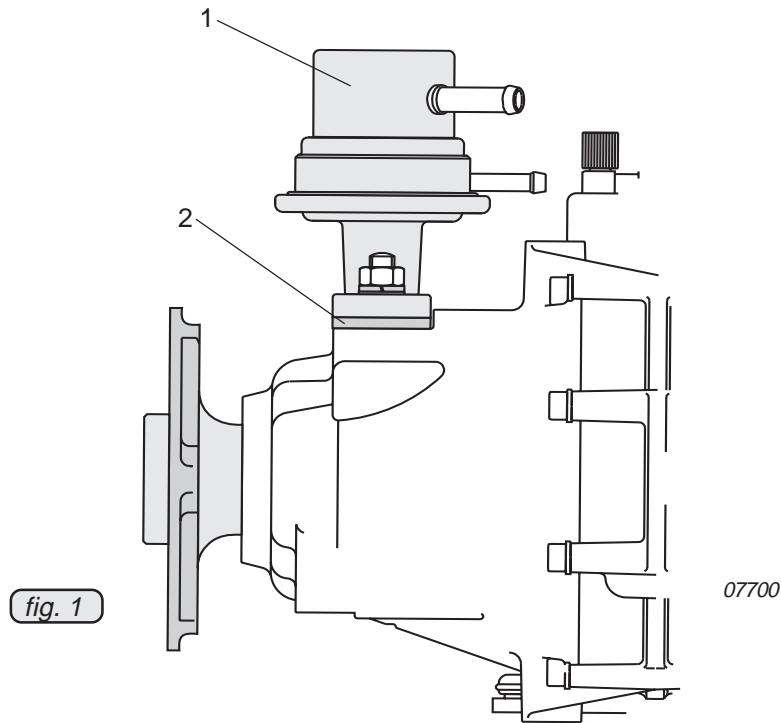

- ◆ NOTE: The illustrations in this document show the typical construction. They may not represent full detail or the exact shape of the parts which have the same or similar function.
Exploded views are **not technical** drawings and are for reference only. For specific detail, refer to the current documents of the respective engine type.